

RFEA NO.	LTR	Description	Eng.	Date	Q.C.	Date
0657	A	ADD ADDITIONAL NOTES, FLANGE SIZES	SM	9-18-00		

MATERIAL:

- 1 ALUMINUM - 6000 SERIES
- 2 ALUMINUM - 6061-T6
- 3 ALUMINUM CASTING LM25TF
- 4 ALUMINUM - CAST 319
FLANGES ARE 5" - 150 LB
MOUNTING HOLES ARE TAPPED FOR 3/4-10 FASTNERS
- 5 SIZE AND TYPE VARIES WITH CUSTOMER REQUIREMENTS.

WEIGHT:

- ITEMS 1, 2 AND 3: 516 LBS (234 Kg)
- ITEM 4: 115 LBS (52.3 Kg)
- ITEM 5: VARIES WITH CUSTOMER REQUIRMENTS

NOTE:

1. IF REQUIRED, THE TRANSITION ADAPTER IS 5" - 150 LB FLANGE X THE SIZE REQUIRED FOR SPECIFIC SITE.

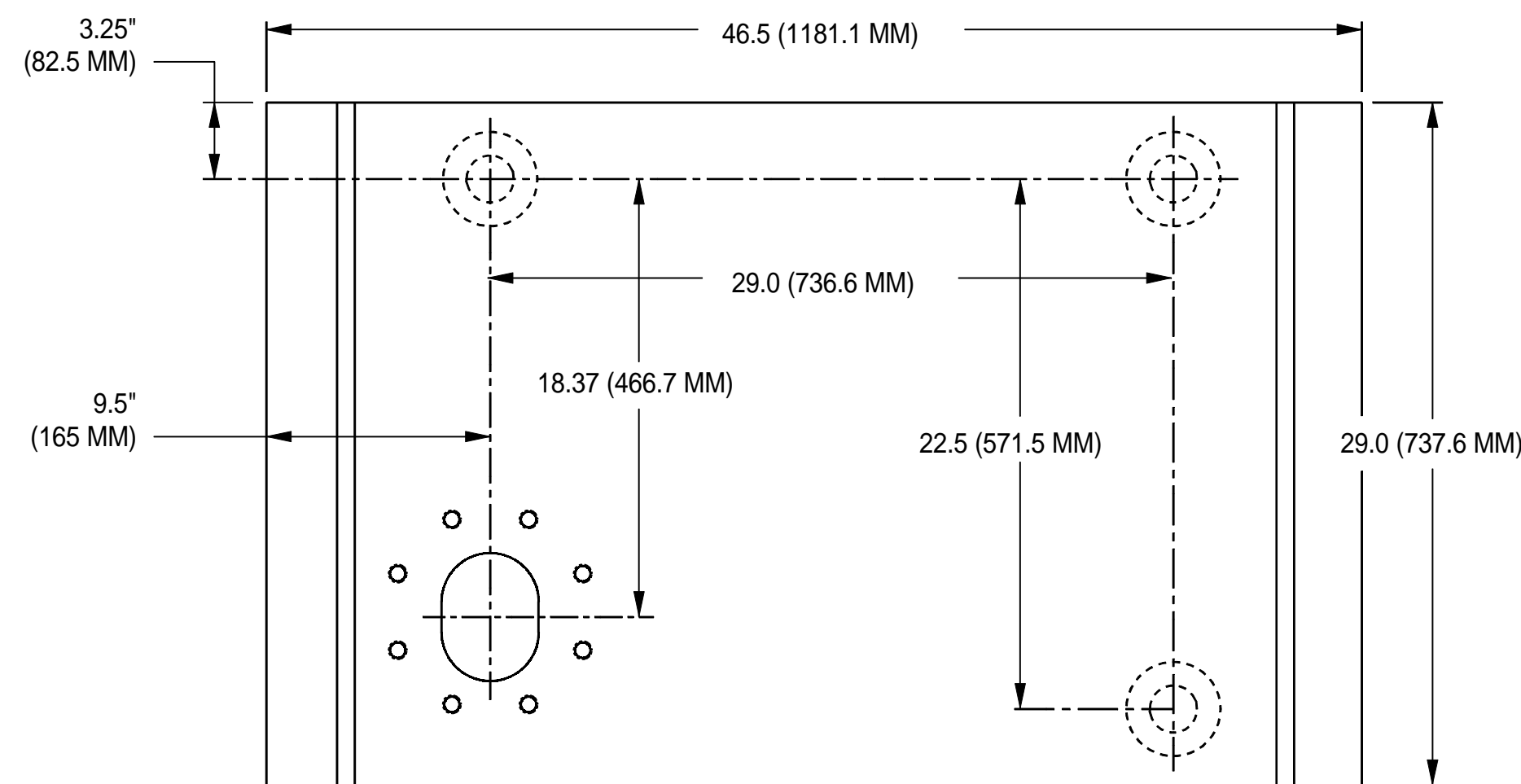
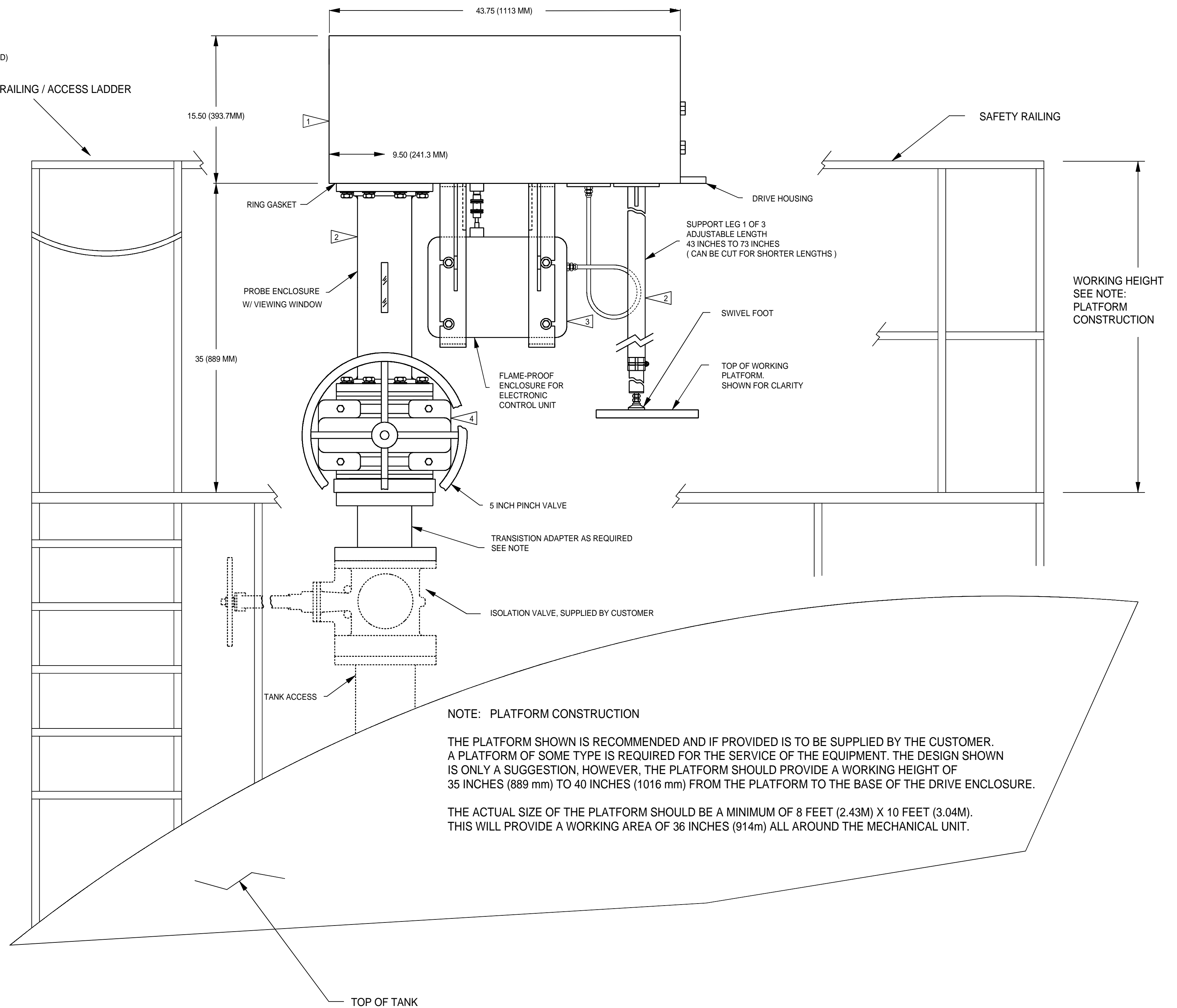
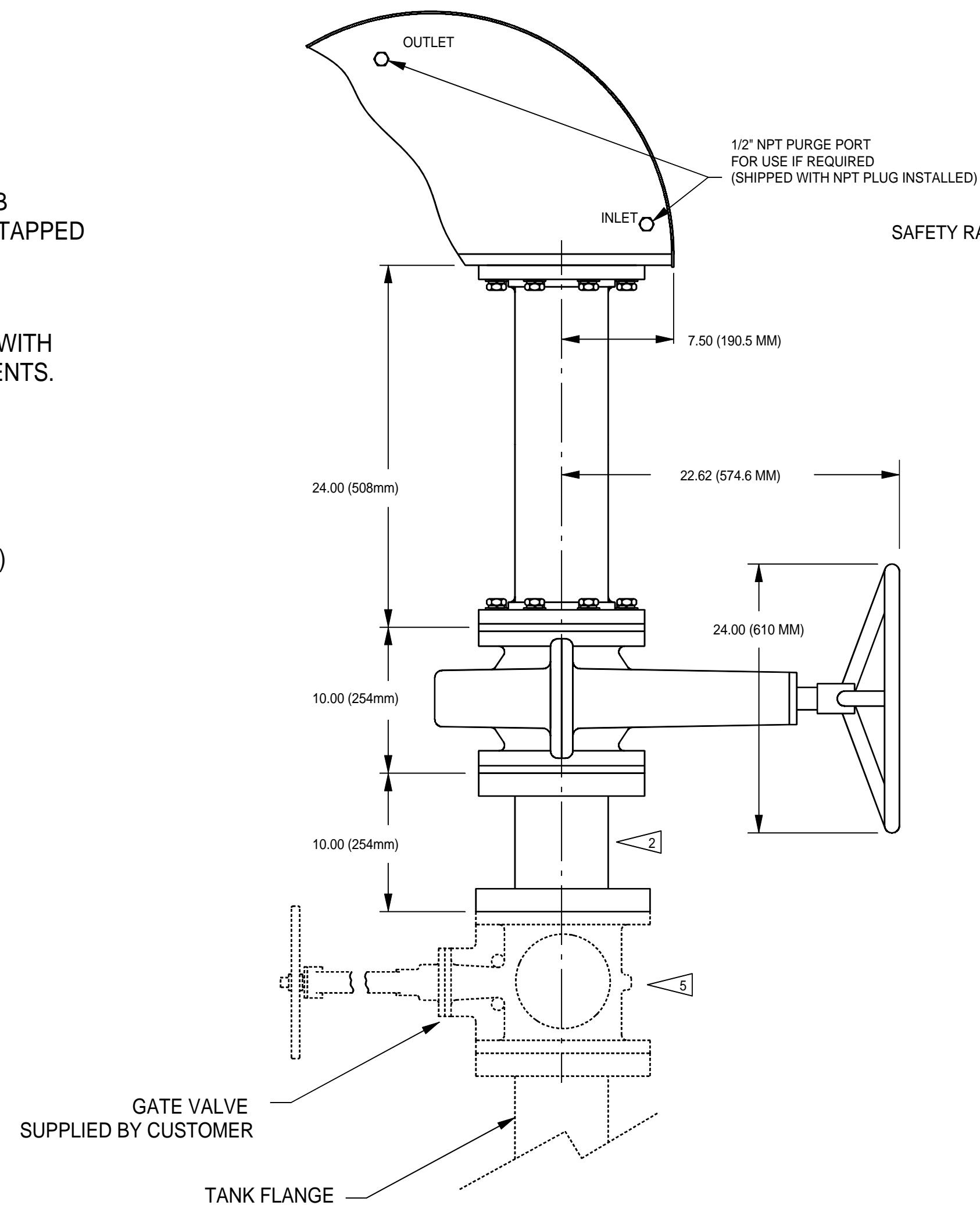

MOUNTING FOOTPRINT - TOP VIEW WITH COVER REMOVED

	Material	Finish	Scale	Dwn.	SM	5-18-00
		32	NONE	Eng.	DS	5-25-00
Tolerance	Title					
.00 +/- .030	TOP-OF-TANK SUB-ASSEMBLIES					
.000 +/- .010	INCLUDING GENERAL LAYOUT AND PLATFORM					
Frac. +/- 1/16	FSCM NO.	Size	Dwg. No.	Rev.	Sheet	
Ang. +/- 1/2 Deg.	53547	D	040-271	A	1 OF 1	
Corners +/- .010						