



## COMPONENT MAINTENANCE MANUAL

### TEMPERATURE SENSOR

Part Number  
B7160

Issued by  
SCIENTIFIC INSTRUMENTS, INC.  
4400 W. Tiffany Drive  
West Palm Beach, FL 33407  
USA

Tel (561) 881-8500  
Fax (561) 881-8556

**21-51-58**

Page T-1/T-2  
Sep 1988  
Rev 3 Dec 09/2003



SCIENTIFIC INSTRUMENTS

COMPONENT MAINTENANCE MANUAL  
B7160

RECORD OF REVISIONS

Revision	REVISION DATE	INSERTION		REVISION	REVISION DATE	INSERTION	
		DATE	BY			DATE	BY
1	02/01/91						
2	03/17/95						
3	12/09/03						





COMPONENT MAINTENANCE MANUAL  
B7160

SERVICE BULLETIN LIST

SERVICE BULLETIN	DATE INSERTED	REV.	SUBJECT



# SCIENTIFIC INSTRUMENTS

## COMPONENT MAINTENANCE MANUAL B7160

### LIST OF EFFECTIVE PAGES

	PAGE	DATE		PAGE	DATE
Title Page	1	DEC 09/2003	Testing and fault isolation	2	DEC 09/2003
	2	BLANK		3	
Record of revisions	1	DEC 09/2003	Disassembly	4	
	2	BLANK		5	DEC 09/2003
Record of temporary revisions	1	DEC 09/2003	Cleaning	5	DEC 09/2003
	2	BLANK		5	DEC 09/2003
Service Bulletin List	1	DEC 09/2003	Check	5	DEC 09/2003
	2	BLANK		5	DEC 09/2003
List of effective pages	1	DEC 09/2003	Repair	5	DEC 09/2003
	2	BLANK		5	DEC 09/2003
Table of Contents	1	DEC 09/2003	Assembly including storage	5	DEC 09/2003
	2	BLANK		6	
Introduction	1	DEC 09/2003	Fits and clearances	6	DEC 09/2003
	2	BLANK		6	DEC 09/2003
Description and operation	1	DEC 09/2003	Special tools, fixtures and equipment	6	DEC 09/2003
	2	BLANK		6	DEC 09/2003
Specifications	1	DEC 09/2003	Illustrated parts list	6	DEC 09/2003
	2				



COMPONENT MAINTENANCE MANUAL  
B7160

TABLE OF CONTENTS

DESCRIPTION AND OPERATION.....	1
SPECIFICATIONS.....	1
TESTING AND FAULT ISOLATION.....	2
DISASSEMBLY.....	4
CLEANING.....	4
CHECK.....	4
REPAIR.....	5
ASSEMBLY INCLUDING STORAGE.....	5
FITS AND CLEARANCES.....	5
SPECIAL TOOLS, FIXTURES, AND EQUIPMENT.....	5
ILLUSTRATED PARTS LIST.....	5



COMPONENT MAINTENANCE MANUAL  
B7160

INTRODUCTION

This manual describes the general configuration The Zone Temperature Control Sensor, Model B7160, manufactured by Scientific Instruments, Inc. Identification data, including part number, serial number, and FAA-PMA data, is engraved on the body of the unit.

This manual is divided into separate sections:

Title Page	Testing and Fault Isolation
Record of Revisions	Disassembly
Record of Temporary Revisions	Cleaning
Service Bulletin Information List	Check
List of Effective Pages	Repair
Table of Contents	Assembly including Storage
Introduction	Fits and Clearances
Description and Operation	Special Tools, Fixtures, and Equipment
Specifications	Illustrated Parts List

Refer to the Table of Contents for the page location of applicable sections.

The quantities in this manual are expressed in English units followed by S.I. units in parenthesis.

This manual will be revised as necessary to reflect current information.





COMPONENT MAINTENANCE MANUAL  
B7160

DESCRIPTION AND OPERATION

1. DESCRIPTION

The Zone Temperature Control Sensor, Model B 7160, consists of two calibrated thermistors, which are enclosed within a stainless steel housing. The thermistor is terminated in a 6-pin hermetically sealed, bayonet-coupled receptacle, which connects to an external temperature control system. Mounting of the unit in the aircraft is accomplished via an external  $\frac{3}{4}$  - 16 threaded section and a hex head configuration, as illustrated in Figure 1.

2. OPERATION

The thermistors respond to changes in temperature of the zone air and provide an output inversely proportional to these changes. The associated temperature controller utilizes this output to regulate the temperature of the associated zone.

The thermistor-to-receptacle connections are as illustrated in Figure 1.

3. SPECIFICATIONS

Receptacle: MS3113H10C6PW  
(or equivalent per MIL-C-26482)

\*Mating Connector: MS3116F106SW  
(or equivalent)

Weight: 3 oz (0.09 kg)

Size:

Probe Diameter: 0.375 in. (9.53 mm)

Overall Length: 2.55 in. (64.77 mm) maximum

Mounting Thread:  $\frac{3}{4}$  - 16 UNF 3A

Mounting Hexagon: 1.00 in. (25.4 mm) across flats

\* This plug is listed for test purposes only, and is not necessarily used on the aircraft.

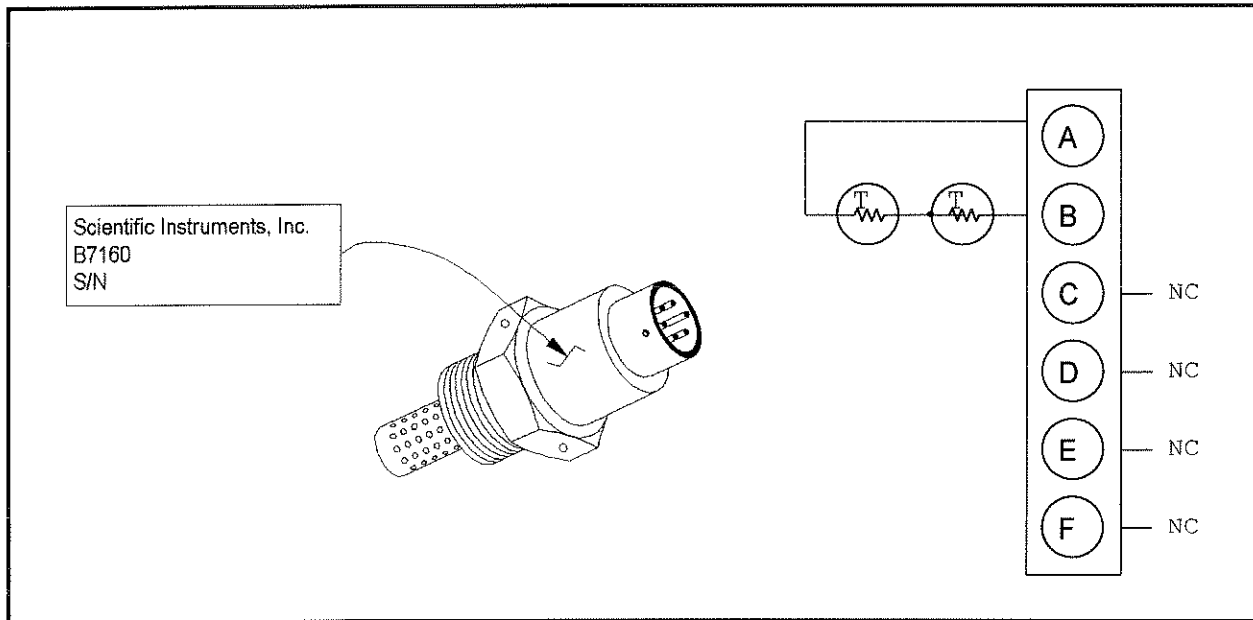

Outline and Schematic Drawing  
Figure 1

### TESTING AND FAULT ISOLATION

#### 4. TESTING AND FAULT ISOLATION

A. The data that follows permits the testing of the sensor to insure correct operation.

B. Special Tools and Test Equipment

- (1) A megohmmeter capable of reading 10 megohms and greater at 500 VDC (AEMC Model 1000, or equivalent)
- (2) Temperature-controlled environmental test chamber. Accuracy 1%.
- (3) Thermometer with temperature accuracy  $\pm 0.2^{\circ}\text{F}$  ( $\pm 0.11^{\circ}\text{C}$ )
- (4) Ohmmeter with:

Current:  $<0.1\text{ mA}$

## COMPONENT MAINTENANCE MANUAL B7160

Accuracy: 0.05%

Range: 0-100 K $\Omega$

### C. Visual Check

- (1) Visually check the sensor for obvious damage.

### D. Insulation Resistance

- (1) Using the megohmmeter, measure the resistance between all receptacle pins and the housing. The reading should exceed 10 megohms @ 500 VDC.

### E. Electrical Test (refer to Figure 2)

- (1) Connect the Ohmmeter to pins A & B of the temperature sensor. Hold the sensor at a temperature of  $75^{\circ}\text{F} \pm 10^{\circ}\text{F}$  ( $23.9^{\circ}\text{C} \pm 5.4^{\circ}\text{C}$ ), within the environmental test chamber. With the thermometer at a stable temperature and located within approximately 1/2 in. (12.7 mm) of the tip of the sensor, measure the temperature. Compare this value to that indicated on Figure 3. The value must be within the limits shown on the drawing.

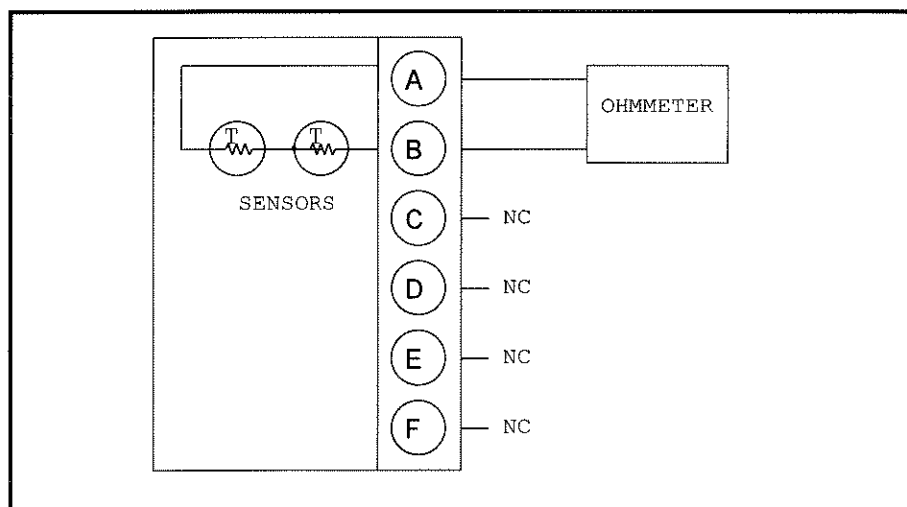

Schematic for Electrical Test

Figure 2

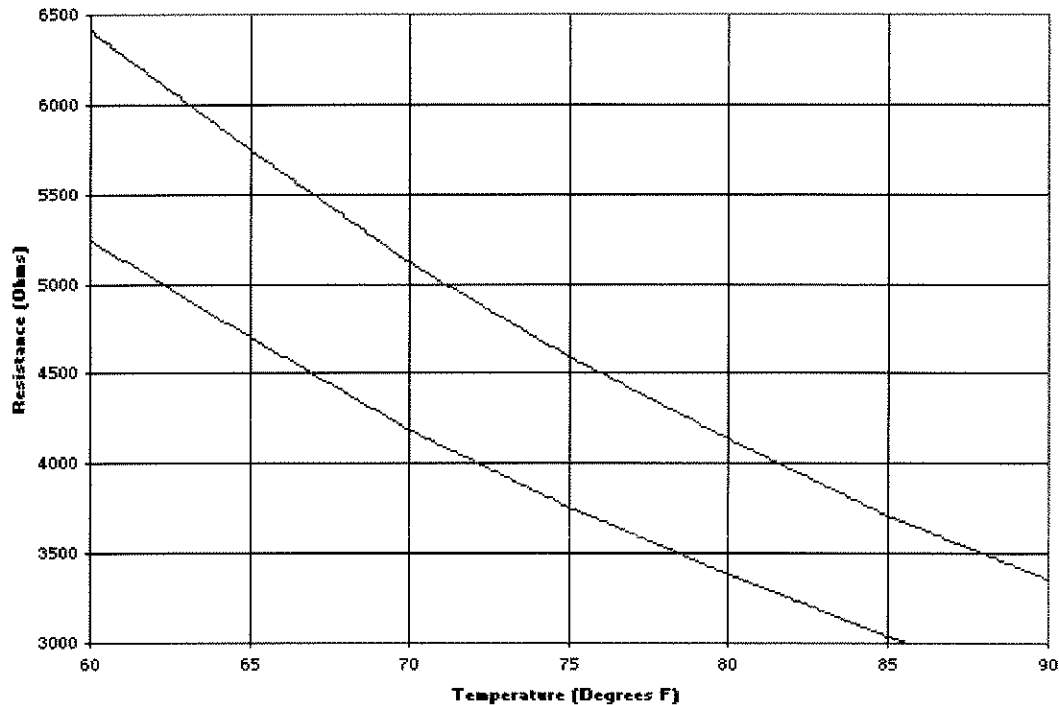

Resistance vs Temperature  
Figure 3

5. DISASSEMBLY

Not Applicable

6. CLEANING

- A. Remove dirt, stains, moisture, etc. with a clean, dry, lint-free cloth.
- B. Use a soft bristle brush moistened in isopropyl alcohol to remove any foreign matter from between the receptacle pins.

7. CHECK

- A. Visually inspect the sensor probe for obvious wear or damage.
- B. Check for bent, broken or missing receptacle pins.



COMPONENT MAINTENANCE MANUAL  
B7160

- C. Check probe housing for scratches or cracks.

## 8. REPAIR

The temperature sensor is considered non-repairable. Bent receptacle pins may be carefully straightened. For other defects or incorrect operation, the temperature sensor should be discarded.

## 9. ASSEMBLY INCLUDING STORAGE

### A. Assembly

Not Applicable

### B. Storage

- (1) Install a protective cap on the electrical connector.
- (2) The sensor must be stored in a clean and dry room open to the air. The temperature must be between 64°F and 82°F (18°C and 28°C) and the relative humidity between 25% and 65%.
- (3) Keep the sensor in its initial packaging. If other containers are put on the sensor container, be careful to prevent damage caused by too much weight.
- (4) Do not keep the sensor near heat, fluids or other sources that can cause corrosion.

## 10. FITS AND CLEARANCES

No dimensional check of the sensor is necessary.

## 11. SPECIAL TOOLS, FIXTURES AND EQUIPMENT

No other special tools are necessary.

## 12. ILLUSTRATED PARTS LIST

Since the unit is non-repairable, no parts list is provided.