



COMPONENT MAINTENANCE MANUAL
B7200

DESCRIPTION AND OPERATION

1. DESCRIPTION

The Duct Air Temperature Sensor consists of two calibrated thermistors, which are connected in series and are mounted within a stainless steel housing. These thermistors are terminated in a 2-pin hermetically sealed receptacle, which connects to an external temperature control system. Mounting of the unit is accomplished via a triangular flange with three mounting holes, as illustrated in Figure 1.

2. OPERATION

The thermistors respond to changes in duct air temperature and provide an output proportional to these changes. The associated temperature controller utilizes this output to regulate the aircraft temperature control system.

The thermistor-to-receptacle connections are as illustrated in Figure 1.

3. SPECIFICATIONS

Receptacle: MS27034H10T20EN
(or equivalent per MIL-C-26500)

*Mating Connector: MS24266R10T205N

Weight: 2.8 oz (0.08 kg)

Size:

Probe Diameter: 0.317 in. (8.1 mm) maximum

Probe Length: 3.03 in. (77.0 mm) maximum

Overall Length: 4.26 in. (106.7 mm) maximum
(excluding connector)

Mounting Thread: mounted via a flange

* This plug is listed for test purposes only, and is not necessarily used on the aircraft.

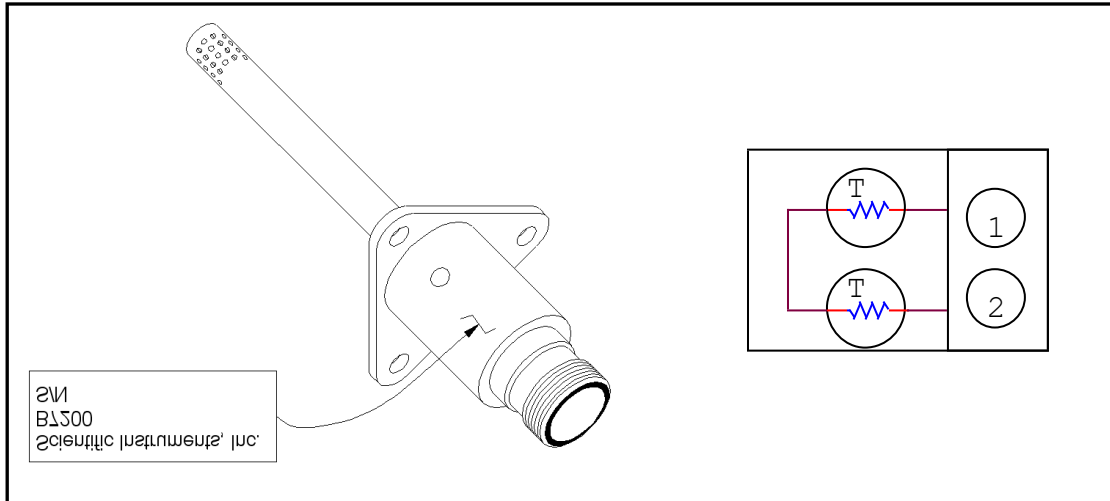

Outline and Schematic Drawing
Figure 1

TESTING AND FAULT ISOLATION

4. TESTING AND FAULT ISOLATION

A. The data that follows permits the testing of the sensor to insure correct operation.

B. Special Tools and Test Equipment

- 1) A megohmmeter capable of reading 10 megohms and greater at 500 VDC (AEMC Model 1000, or equivalent)
- 2) Temperature-controlled environmental test chamber. Accuracy 1%.
- 3) Thermometer with temperature accuracy $\pm 0.2^{\circ}\text{F}$ ($\pm 0.11^{\circ}\text{C}$)
- 4) Ohmmeter with:

Current: $<0.1 \text{ mA}$

Accuracy: 0.05%

Range: 0-100 $\text{K}\Omega$

C. Visual Check

- 1) Visually check the sensor for obvious damage.

D. Insulation Resistance

- 1) Using the megohmmeter, measure the resistance between all receptacle pins and the housing. The reading should exceed 10 megohms @ 500 VDC.

E. Electrical Test (refer to Figure 2)

- 1) Connect the Ohmmeter to pins 1 & 2 of the temperature sensor. Hold the sensor at a temperature of $32^{\circ}\text{F} \pm 3^{\circ}\text{F}$ ($0^{\circ}\text{C} \pm 1.6^{\circ}\text{C}$), within the environmental test chamber. With the thermometer at a stable temperature and located within approximately 1/2 in. (12.7 mm) of the tip of the sensor, measure the temperature. Compare this value to that indicated on Figure 3. The value must be within the limits shown on the drawing.
- 2) Connect the Ohmmeter to pins 1 & 2 of the temperature sensor. Hold the sensor at a temperature of $160^{\circ}\text{F} \pm 5^{\circ}\text{F}$ ($71.1^{\circ}\text{C} \pm 2.8^{\circ}\text{C}$), within the environmental test chamber. With the thermometer at a stable temperature and located within approximately 1/2 in. (12.7 mm) of the tip of the sensor, measure the temperature. Compare this value to that indicated on Figure 4. The value must be within the limits shown on the drawing.

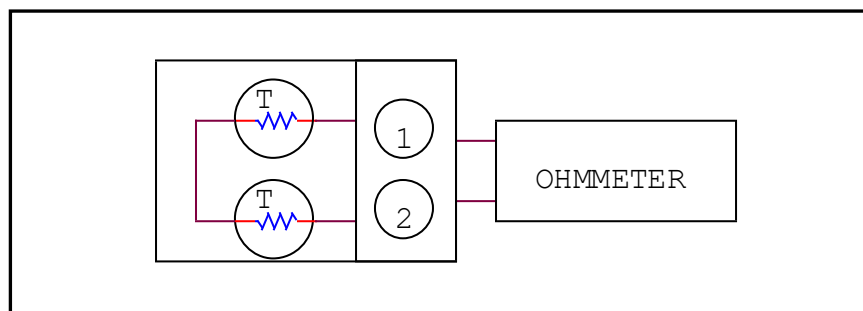

Schematic for Electrical Test
Figure 2



COMPONENT MAINTENANCE MANUAL
B7200

Resistance vs Temperature

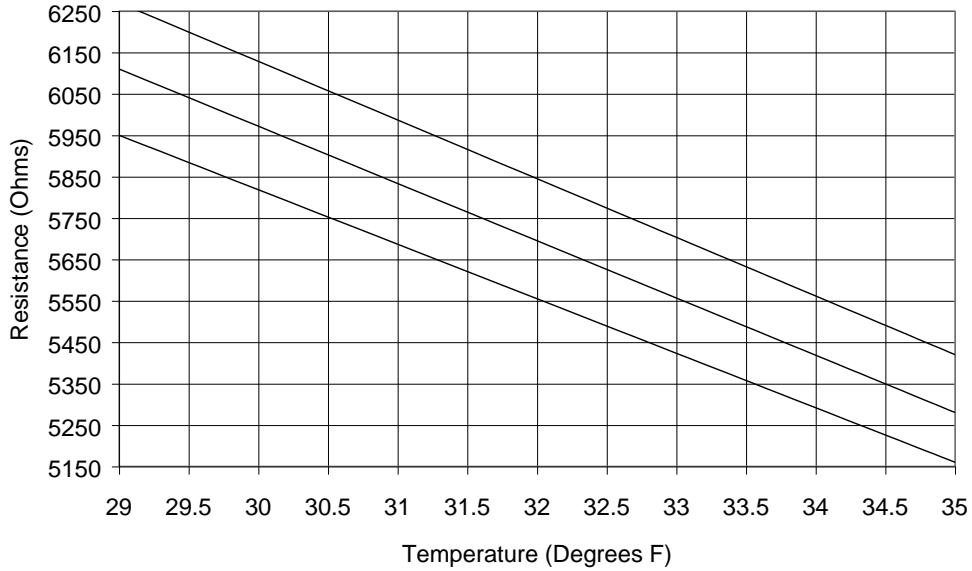

Resistance vs Temperature
Figure 3

Resistance vs Temperature

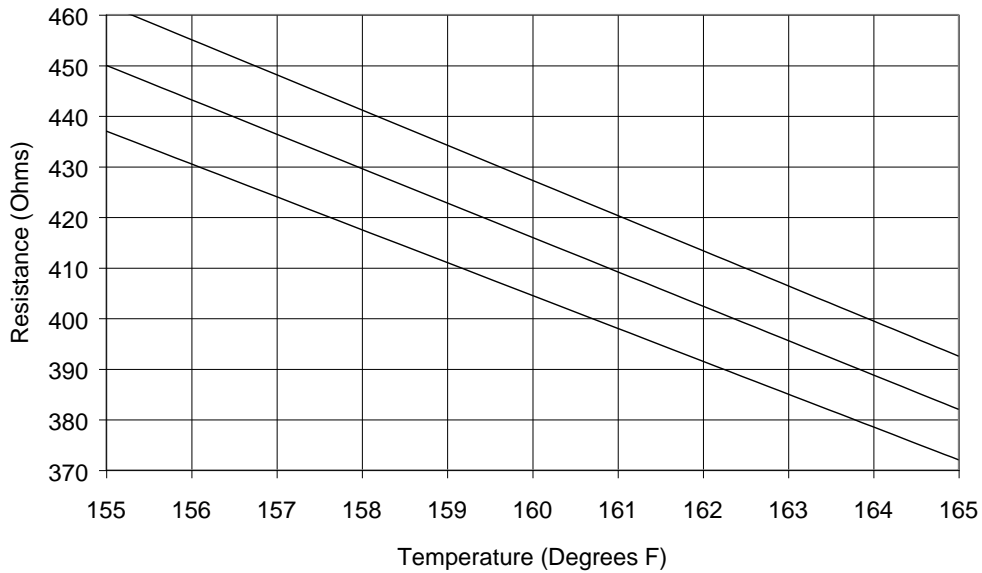

Resistance vs Temperature
Figure 4



COMPONENT MAINTENANCE MANUAL
B7200

5. DISASSEMBLY

Not Applicable

6. CLEANING

- A. Remove dirt, stains, moisture, etc. with a clean, dry, lint-free cloth.
- B. Use a soft bristle brush moistened in isopropyl alcohol to remove any foreign matter from between the receptacle pins.

7. CHECK

- A. Visually inspect the sensor probe for obvious wear or damage.
- B. Check for bent, broken or missing receptacle pins.
- C. Check probe housing for scratches or cracks.

8. REPAIR

The temperature sensor is considered non-repairable. Bent receptacle pins may be carefully straightened. For other defects or incorrect operation, the temperature sensor should be discarded.

9. ASSEMBLY INCLUDING STORAGE

A. Assembly

Not Applicable

B. Storage

- 1) Install a protective cap on the electrical connector.
- 2) The sensor must be stored in a clean and dry room open to the air. The temperature must be between 64°F and 82°F (18°C and 28°C) and the relative humidity between 25% and 65%.



COMPONENT MAINTENANCE MANUAL
B7200

- 3) Keep the sensor in its initial packaging. If other containers are put on the sensor container, be careful to prevent damage caused by too much weight.
- 4) Do not keep the sensor near heat, fluids or other sources that can cause corrosion.

10. FITS AND CLEARANCES

No dimensional check of the sensor is necessary.

11. SPECIAL TOOLS, FIXTURES AND EQUIPMENT

No other special tools are necessary.

12. ILLUSTRATED PARTS LIST

Since the unit is non-repairable, no parts list is provided.